



Publisher

<http://jssidoi.org/esc/home>



DEVELOPING SOCIAL ENTREPRENEURSHIP: A STUDY OF COMMUNITY PERCEPTION IN INDONESIA

Hardi Utomo¹, Sony Heru Priyanto², Lieli Suharti³, Gatot Sasongko⁴

^{1,2,3,4} Satya Wacana Christian University, Faculty of Economics and Business, Diponegoro 52-60, Salatiga 50711, Indonesia

E-mails: ¹ utomohardi@yahoo.com; ² sonecid@yahoo.com; ³ lieli.suharti@staff.uksw.edu;
^{4*} gatot.sasongko@staff.uksw.edu (corresponding author)

Received 17 January 2019; accepted 25 June 2019; published 30 September 2019

Abstract. Nowadays, the understanding of social entrepreneurship is still diverse. This study aims to create a model of social entrepreneurship and the factors shaping it. The results of this study indicated that there was a direct, positive influence of the organizational environment, social environment, individual characteristic, experience, and family demands for entrepreneurship, while the economic environment, education and training had no significant influence on the entrepreneurship. Furthermore, the results of the analysis proved that the organizational environment, variables, social environment, economic environment, individual characteristic, education and training, experience, and family demands indirectly influenced the social entrepreneurship through entrepreneurship variables as the intervening variables, except for the economic environment variable. The research method used was Structural Equation Model (SEM). SEM is a multivariate analysis used to analyze the relationships between variables in a complex manner. Authors used non-probabilistic sampling with 320 respondents. Authors strive to examine the role of government in providing capital, and universities in creating new social entrepreneurs that contribute to the tightening of social problems in the further research.

Keywords: Entrepreneurship; Social Entrepreneurship; Indonesia

Reference to this paper should be made as follows: Utomo, H.; Sony Priyanto, H.; Suharti, L.; Sasongko, G. 2019. Developing social entrepreneurship: a study of community perception in Indonesia, *Entrepreneurship and Sustainability Issues* 7(1): 233-246. [http://doi.org/10.9770/jesi.2019.7.1\(18\)](http://doi.org/10.9770/jesi.2019.7.1(18))

JEL Classification: M14, M20

1. Introduction

Entrepreneurship is an art and science that has contributed greatly to the business world. The traditional theory of entrepreneurship states that entrepreneur is someone who creates a new business in a risky and uncertain environment for profit purpose (Kirzner, 1973; Abdulmelike, 2017; Daud et al., 2018). The traditional theories emphasize entrepreneurship in terms of risk-oriented and individual profit seeking. However, along with developments and changes in the business environment, there is a shift in understanding of entrepreneurship. Now it does not only emphasize achieving individual profit, but also focuses on how entrepreneurial activities can

contribute socially (Mair & Noboa, 2003; Abdulmelike, 2017; Myres et al., 2018; Buchko, 2018; Daud et al., 2018; Kimmit & Muñoz, 2018; European Commission, 2018; Sannikova & Brante, 2018).

Prabhu (1999) described social entrepreneurs as people who make or manage innovative entrepreneurial organizations, and whose main mission is social changes and development of community groups. According to him, social entrepreneurship is the process of construction, evaluation, and the pursuit of opportunities for transformative, energetic and dedicated social changes (Kimmit & Muñoz, 2018). According to Sharir and Lerner (2006), social entrepreneurs act as agents of change to create and maintain social values without being limited to the existing resources. The social entrepreneurs aim to create value in the form of transformational changes that will benefit the poor and ultimately, the wider community (Abdulmelike, 2017; Myres et al., 2018; Buchko, 2018; Kimmit & Muñoz, 2018; Sannikova & Brante, 2018; Prodanov, 2018).

Although social entrepreneurship has many similarities to traditional entrepreneurship; for example, these two forms of entrepreneurship together create a new activity or organization in the social environment. The key differences between these two forms of entrepreneurship are: owners or actors of social entrepreneurship are not merely encouraged by the desire to gain profit, but, more importantly, they strive to solve social problems in their environment and to create social values. With a focus on social changes and social development, the social entrepreneurs have a significant impact on the society, both socially and economically (Mair & Noboa, 2003; Kimmit & Muñoz, 2018). Hibbert et al. (2005) revealed that social entrepreneurship is the use of entrepreneurial behavior, which tends to be more oriented to the achievement of social purposes and does not prioritize the profit, or if there is any profit, it is used for social purposes.

The results of the study by Mair and Noboa (2003) showed that the interest in social entrepreneurship came from several factors influencing the entrepreneurial behavior. They added that the model of social entrepreneurship, which was specifically related to the social entrepreneurship intention, was influenced by cognitive factors (character and moral) and individual characteristic factors (emotions and empathy), making the social entrepreneur focuses on helping others (Prodanov, 2018). While Mort (2003) revealed that the factors influencing the entrepreneurship were not only limited to individual factors, because they were not enough to picturize the entrepreneurial process as a whole. He also further mentioned that it was because the entrepreneurial activity also involved organizations, economic environment, and social support, resulting in the environmental factors to be external factors which could complement the entrepreneurial activities. The results of Nicholls (2006) study showed that based on the level of organizational, the social entrepreneurship could be seen from two elements. The first was to focus on social mission, which reflected in the context and output of the actions according to the social values showed in the surrounding environment after the organization carried out its activities. The second was the operational process - the approach to action with an 'entrepreneurial' component. These components indicated the individual behavior of an entrepreneur. From the results of these studies, it can be seen that external factors influence entrepreneurship such as: individual characteristicistics, organizational, social, and economic environment also have a relationship with the formation of social entrepreneurship model. Based on these explanations, there is a strong belief that there is a connection between these external factors influencing the formation of social entrepreneurship model (Kimmit & Muñoz, 2018).

A previous research by Priyanto (2004) explained that internal factors of entrepreneurship were the aspects that proposed and shaped the spirit of entrepreneurship. Entrepreneurship is basically for everyone because it can be learned. According to Drucker (1996), every person who has the courage to make decisions can learn to become and behave like an entrepreneur. It is because entrepreneurship is more of a behavior than a personality phenomenon, which basically lies in the concepts and theories, not an intuition (Abdulmelike, 2017; Sannikova & Brante, 2018; Daud et al., 2018). Further, the entrepreneurial spirit of a person can be formed through several aspects, including: individual characteristic, education and training, experience, parenting, and family demands.

These factors are the internal factors that can also shape the spirit of social entrepreneurship (Hisrich & Peters, 1992; Kimmit & Muñoz, 2018; Daud et al., 2018).

Based on the research results explained previously, in a broad outline, it can be concluded that social entrepreneurship is one of the positive ways or alternatives in overcoming various social problems these days. Research studies on social entrepreneurship are interesting, and need to be carried out. However, it has not been discussed on how the entrepreneurship model can be created, the linkages between entrepreneurial variables in general and social entrepreneurship have not yet emerged. Previous researches considered entrepreneurship as a separate part of social entrepreneurship (McMullen, 2011). On the other hand, the results of a study by Estrin et al. (2013) showed that the high number of commercial entrepreneurs in one country will determine the number of social entrepreneurs. Therefore, it can be concluded that there is a link between commercial entrepreneurship and social entrepreneurship (Myres et al., 2018).

It is explained formerly that there is an inconsistency in the results between McMullen's (2011) and Estrin et al.'s (2013) studies, which makes it a space for this present study. A question is then followed whether entrepreneurship is related to social entrepreneurship or not. The answer of this question is what this research is about. Thus, the main objective of this study is to understand whether there is a direct link between entrepreneurship and social entrepreneurship. Entrepreneurship will be the antecedent of the social entrepreneurship.

The method that can be used to analyze the Construction of Social Entrepreneurship Model is the Structural Equation Modeling (SEM) method. According to Santoso (2010), SEM analysis is a complex multivariate analysis as it involves a number of interconnected independent and dependent variables to form a model. However, it cannot simply be concluded that there is a dependent and independent variable in SEM because an independent variable can be dependent on another relationship.

2. Literature Review and Hypothesis Development

2.1 Entrepreneurship

Entrepreneurship is considered as a spirit, ability, attitude, individual behavior in handling business or activities that lead to efforts to find, create, and implement work methods, technology and new products by increasing efficiency in order to provide better services and or gain greater profits (Drucker, 1996; Siagian & Ashafani, 1995; Riyanti, 2003; Prodanov, 2018; Buchko, 2018; Shannikova & Brante, 2018; Shin, 2018). Based on this definition, it indicates that entrepreneurship is the ability to create something new and different through creative thinking and innovative action to create opportunities in facing life's challenges. This ability is based on the nature, characteristics, and character of someone who has the will to realize the innovative ideas into the real world creatively. It is a process of identifying, developing, and bringing visions into life. This vision can be in the form of innovative ideas, opportunities, and better ways of doing things. The final result of the process is the creation of new businesses formed in conditions of risks or uncertainties (European Commission, 2018).

2.2 External Factors of Entrepreneurship

2.2.1 Organizational Environment

Organizational environment refers to the result of actions in an organizational climate that can influence the behavior of its members (Wijono, 2005; Abdulmelike, 2017; Buchko, 2018; Prodanov, 2018). Someone who lives and is raised in a conducive and challenging, open and flexible organizational environment will be a successful entrepreneur who has a large motivation, is independent and responsive to risks (Buchko, 2018; Prodanov, 2018).

2.2.2 Social Environment

Social environment refers to a social climate exists around individual groups and is based on mutually agreed upon personal values (Reppeti, 2007; Kimmit & Muñoz, 2018). Social factors (such as network and support from the socio-political elite), economic factors (such as the availability of capital, aggregate indicators, recession and unemployment), political conditions (such as support from other institutions, regulations) and infrastructure factors (such as the education system, labor market, access to information and availability of assets) will greatly influences one's intentionality and decision making in conducting business activities (Mazzarol et al., 1999; Prodanov, 2018).

2.2.3 Economic Environment

Economic environment refers to an economic condition in an organizational environment. High unemployment is one of the factors that influence a person to create his own employment by becoming entrepreneurs (Sadoulet & Janvry, 1995; Buchko, 2018; Prodanov, 2018). The level of economic growth of a country also determines the development of entrepreneurship (Kadarsih et al, 2013; Abdulmelike, 2017; Buchko, 2018; Prodanov, 2018).

2.3 Internal Factors of Entrepreneurship

2.3.1 Individual Characteristic

Individual characteristic refers to a tendency that characterizes individuals, which distinguishes an individual from other individuals and becomes the basis for behavior (Crant, 2000; Abdulmelike, 2017; Shin, 2018; Kimmit & Muñoz, 2018). The character of entrepreneurs can be seen based on six characteristics of entrepreneurs, namely confidence, task and results-oriented, courage to take risks, leadership, originality, future-oriented, and that the characteristics of entrepreneurs and the aspects of entrepreneurship are equivalent (Meredith et al., 1996; Myres et al., 2018; Shin, 2018; Buchko, 2018; Prodanov, 2018; Mohapatra et al., 2018).

2.3.2 Education and Training

A person's entrepreneurial spirit can be formed through several aspects, and some of them are through education and work history (Hisrich & Peters, 1992; Buchko, 2018; Kimmit & Muñoz, 2018). The only battle to make humans with moral, attitude and entrepreneurial skills is through education. Education gives many insights for individuals to be more confident; able to choose and make right decisions; increase creativity and innovation; foster moral, character, and intellectual; and improve the quality of other human resources, so that they are finally able to stand on their feet (Soemanto, 2002; Sannikova & Brante, 2018; European Commission, 2018).

2.3.3 Experience

Learning experience refers to an interaction, between those who learn with their environment, where they can react to stimuli they receive (Soekanto, 1986; Kimmit & Muñoz, 2018; Shin, 2018; Mohapatra et al., 2018; European Commission, 2018; Gandhi & Raina, 2018). Someone's experience will contribute to their interests and hopes to learn more. Based on the organizational context, work experience of employees in carrying out tasks in an organization plays a very important role (Dahama & Bhatnagar, 1980; Gandhi & Raina, 2018).

2.3.4 Family Demands

Family demands play a significant role in job selection, although this is also, sometimes, not realized by the respective individual (Mustofa, 1996; Buchko, 2018). It can be a driving force for individuals to do their jobs including entrepreneurship (Greenhaus & Singh, 2003; Prodanov, 2018).

2.4 Social Entrepreneurship

Social entrepreneurship refers to an effort to create innovative solutions to overcome urgent social problems by working on the ideas, capacity, resources, and social agreements, so that sustainable social change can occur (Alvord et al., 2004; Bornstein, 2004; Thompson et al., 2000; Abdulmelike, 2017; Daud et al., 2018).

2.5 Hypothesis Development

2.5.1 The Influence of Environment towards Entrepreneurship

Organizational environment refers to the result of actions in an organizational climate that can influence the behavior of its members (Wijono, 2005; Abdulmelike, 2017; Buchko, 2018; Prodanov, 2018). Someone who lives and is raised in a conducive and challenging, open and flexible organizational environment will be a successful entrepreneur who has a large motivation, is independent and responsive to risks. The strategies and plans implemented, existing financial resources, industry sector and business format will influence one's entrepreneurial behavior (Watson & Scott, 1988; Shin, 2018). In addition, social environment is a social climate exists around individual groups and is based on agreed personal values (Reppet, 2007; Buchko, 2018). Lambing and Kuehl (2000) stated that a person's level of entrepreneurship varies greatly according to the culture in which he has a social environment. Meanwhile, the economic environment refers to the economic conditions within the organizational environment (Sadoulet & Janvry, 1995; Abdulmelike, 2017). As stated by Kadarsih et al. (2013), the level of economic growth of a country also determines the development of entrepreneurship. Individual characteristics are the tendencies that characterize individuals who differentiate them from other individuals and become the basis of behavior (Crant, 2000; Crant, 2000; Abdulmelike, 2017; Shin, 2018; Kimmit & Muñoz, 2018). Meredith et al. (1996) compiled the entrepreneurial characteristics based on six entrepreneurial characteristics and stated that entrepreneurial characteristics with entrepreneurial aspects were equivalent. According to Hisrich and Peters (1992), a person's entrepreneurial spirit can be formed through several aspects, such as through education, and work history. Training is a learning process which utilizes several methodological techniques to improve skills and abilities of one's job (Nasution, 2003; Buchko, 2018; Kimmit & Muñoz, 2018). The importance of education in fostering the spirit of entrepreneurship is also stated by Zimmerer (2002). Dahama and Bhatnagar (1980) explained that a person's experience will contribute to his interests and hopes to learn more. Alwi (2001) also added that experience is the level of mastery of a person's knowledge and skills which can be measured from a person's work period. Likewise, in the context of entrepreneurship, the more entrepreneurial experiences a person has, the better the person will be to master his work, resulting him to finish his job well. Finally, the last is variable family demands. According to Mustofa (1996), family demands play a significant role in job selection, although this is also, sometimes, not realized by the respective individuals. Further, the entrepreneurial behavior of street vendors were highly related to family demand factors. Family demands are the amount of energy, time, and roles needed to handle the fulfillment of household needs and tasks (Greenhaus & Singh, 2003; Prodanov, 2018). Family demands can be a driver for individuals to do their jobs including entrepreneurship. From the description above, it can be explained that these factors can influence entrepreneurship.

H1: Organizational, social, and economic environment, individual characteristic, education and training, experience, and family demands influence entrepreneurship.

2.5.2 The Influence of Environment towards Social Entrepreneurship

According to the definition, social entrepreneurship refers to a social innovation that aims to create social value generated through a collaboration of a group of people and organizations from a social environment that influences a social entrepreneurship (Hubbard, 2010; Abdulmelike, 2017; Buchko, 2018; Prodanov, 2018). Experts in social entrepreneurship, Dees (1998), stated that social entrepreneurship is a combination of great enthusiasm in social mission with discipline, innovation, and determination as what customary in the business world is. Furthermore, Dees (1998) explained that social entrepreneurship is the use of innovation to create an economic activity that has social values from a combination of resources to get the opportunities by leading to the formation of organizations and or practices produced and making social changes, resulting it to be impossible to be separated from the activities in the economic environment. Individual characteristics can be a determinant of social entrepreneurial intention in a person (Prieto, 2011; Abdulmelike, 2017; Shin, 2018; Kimmit & Muñoz, 2018). The external and internal factors include organizational environment, social environment, economic environment, individual characteristic, education and training, experience, and family demands that shape entrepreneurship (Hisrich & Peters, 1992; Abdulmelike, 2017; Buchko, 2018; Prodanov, 2018; Kimmit & Muñoz,

2018; Wijono, 2005; Reppeti, 2007). This is also in line with Hulgard's (2010) opinion that there is a link between entrepreneurship and social entrepreneurship. Therefore, a hypothesis that can be proposed is as follows:

H2: Organizational environment, organizational environment variables, economic environment variables, individual characteristic, education and training, experience, and family demands influence social entrepreneurship.

2.5.3 The Influence of Entrepreneurship towards Social Entrepreneurship

Entrepreneurship as a basic concept can be considered as an intervening variable between the influence of external and internal factors on social entrepreneurship (Kimmit & Muñoz, 2018; Daud et al., 2018). This is supported by the research conducted by McMullen (2011) that previous researches looked at entrepreneurship as an integral part of social entrepreneurship.

H3: Entrepreneurship influences social entrepreneurship.

2.5.4 The Influence of External and Internal Environment towards Social Entrepreneurship with Entrepreneurship as an Intervening Variable

Estrin et al. (2013) stated that the higher the number of commercial entrepreneurs in a country, the higher the number of social entrepreneurs. In addition, Gandhi and Raina (2018) also explained that social entrepreneurship is such an effort to create "Social Wealth", so that there is a strong attachment between the social entrepreneurial actors and the community groups assisted. According to Alvord (2002), the intention of social entrepreneurship may come from business entrepreneurial activities, ideas for creating social values and benefits, identifying social problems, or creating activities that can contribute to a social environment which may come from one person. However, it still requires resources, volunteers, government support, and donations (European Commission, 2018; Kimmit & Muñoz, 2018; Sannikova & Brante, 2018).

H4: Organizational environment, social environment, economic environment, individual characteristic, education and training, experience, and family demands influence social entrepreneurship with entrepreneurship as an intervening variable.

2. Measurement of Variables

The variables used in the study are divided into latent variables and empirical indicators, which can be seen in Table 1.

Table 1. Latent Variables and Empirical Indicators

Latent Variables	Empirical Indicators
Organizational Environment (X1)	<ol style="list-style-type: none"> 1. Involvement in a decision-making process (X1.1) 2. Trust (X1.2) 3. Cooperation (X1.3) 4. Attitude in dealing and resolving problems (X1.4) 5. Leader feedback (X1.5) 6. Performance evaluation (X1.6)
Social Environment (X2)	<ol style="list-style-type: none"> 1. Acceptable values (X2.1) 2. Networking (X2.2) 3. Culture (X2.3) 4. Lifestyle (X2.4) 5. Social class (X2.5) 6. Applicable laws (X2.6)
Economic Environment (X3)	<ol style="list-style-type: none"> 1. Unemployment rate (X3.1) 2. Availability of capital (X3.2) 3. Interest rate (X3.3) 4. Availability of inputs / raw materials (X3.4) 5. Economic growth rate (X3.5)
Individual characteristic (X4)	<ol style="list-style-type: none"> 1. Confidence (X4.1) 2. Tenacity (X4.2)

	<ol style="list-style-type: none"> 3. Leadership (X4.3) 4. Originality (X4.4) 5. Future-oriented (X4.5)
Education and Training (X5)	<ol style="list-style-type: none"> 1. Increased knowledge (X5.1) 2. Improved individual skills along with technological development (X5.2) 3. Ability to solve operational problems (X5.3) 4. Stimulating accuracy of decision-making (X5.4) 5. Increased workability (X5.5)
Experience (X6)	<ol style="list-style-type: none"> 1. Length of time of entrepreneurship (X6.1) 2. Level of knowledge owned (X6.2) 3. Level of technical skills and abilities, to assess the abilities in technical works implementation (X6.3) 4. Able to face difficulties at work (X6.4) 5. Able to manage the conflicts at work (X6.5)
Family Demands (X7)	<ol style="list-style-type: none"> 1. Number of dependent family members (X7.1) 2. Composition of family members (X7.2) 3. Meeting the economic needs of the family (X7.3) 4. Family time demands (X7.4) 5. Attention and encouragement from the family (X7.5)
Entrepreneurship (Y1)	<ol style="list-style-type: none"> 1. Risk taking (Y1.1) 2. Taking advantage of opportunities (Y1.2) 3. Creating a new business (Y1.3) 4. Creative (Y1.4) 5. Innovative approach (Y1.5) 6. Independent (Y1.6)
Social Entrepreneurship (Y2)	<ol style="list-style-type: none"> 1. Creating social value (Y2.1) 2. Making social changes (Y2.2) 3. Economic activity (Y2.3) 4. Community empowerment (Y2.4) 5. Resource mobilization (Y2.5)

Source: the authors

3. Research Method

The use of SEM as a form of analysis tool, besides being based on the reasons for the complexity of the model used, is also based on the limitations of multidimensional analysis tools used in quantitative research, such as multiple regression, factor analysis, discriminant analysts and others. SEM examines a series of interdependent relationships between variables simultaneously. This technique is especially useful when the independent variables are in the next equation. In SEM, researchers can carry out three activities simultaneously, namely examining the validity and reliability of the instrument, obtaining a relationship model that is useful for estimation (Gozali, 2014). The population of this study were 1570 people. The sample used were 320 respondents (Salatiga City = 116; Demak Regency = 204). The population was taken from the beneficiaries of social entrepreneurial benefits.

4. Data Analysis and Findings

4.1 Data Analysis

The overall results of the questionnaire are more than 0.1156. Therefore, a valid questionnaire could be based on the significance value of $r_{count} > r_{table}$. This resulted in the valid questions, which could be used for analysis. Further, the results of the analysis showed that the reliability test value is more than 0.60 for all variables studied.

4.2 Model and SEM Equation Conversion

Confirmatory factor analysis (CFA) examined whether the actions of the construct are consistent with a researcher's understanding of the nature of the construct or factor. Thus, the purpose of confirmatory factor analysis was to examine whether the data could be used in the hypothesis measurement model (Harrington, 2009). In Figure 1 CFA of the research variables is presented.

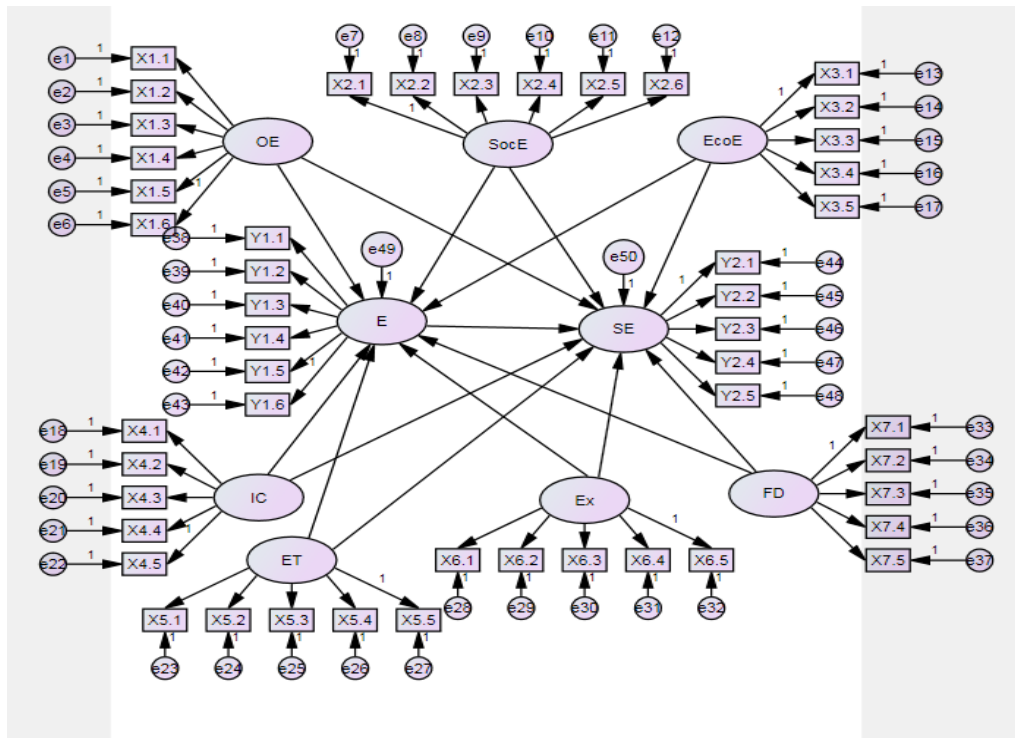

Figure 1. Confirmatory Factor Analysis of the Research Variables
 Source: the authors

4.3 SEM Assumption Test

4.3.1 Outliers Test

The examination of multivariate outliers was carried out by using the Mahalanobis criteria at the level of $p < 0.001$. Mahalanobis distance (Md) was evaluated using χ^2 at the free degree of the number of parameters in the model used, namely 1065 where the statistical table is 990.24. The decision-making rules are: if the Md from the observation point is > 990.24 , then it shows that the observation point is an outlier, whereas if the Md from the observation point is < 990.24 , then it shows that the observation point is not an outlier. Based on the Mahalanobis distance table, it can be seen that the observation point has an Md value between 61.672 to 205.233 for which all of these values are smaller than 990.24. Therefore, it could be concluded that all observation points were not outliers. Thus, the assumption of outliers was fulfilled.

4.3.2 Normality Test

AMOS output shows that the CR Multivariate Normality value of 95.079 is greater than the required value of 1.96. Thus, the assumption of normality had not been fulfilled. However, based on the central limit argument, if the sample was larger, the statistics will be normally distributed. With a sample size of 100, the data was considered to fulfill the central limit argument. Therefore, the assumption of normality of data was not critical and could be ignored. After the structural model was made, the next step was to test it. The goodness of fit test must

be done to ensure that the structured model prepared could explain the direction of the relationship and the influences appropriately and did not cause estimation biases. The result can be seen in Table 2.

Table 2. Result of Overall Goodness of Fit Test

Criteria	Cut-of value	Result	Conclusion
Chi Square	Small	2906.225	Not Fit
p-value	ϵ 0.05	0.00	
CMIN/DF	\leq 2.00	1.729	Good Fit
RMSEA	\leq 0.08	0.078	Good Fit
GFI	ϵ 0.90	0.664	Not Fit
AGFI	ϵ 0.90	0.629	Not Fit
TLI	ϵ 0.95	0.560	Not Fit
CFI	ϵ 0.95	0.585	Not Fit

Source: the authors

The results of the overall goodness of fit, based on the figure and the table, it shows that the 2 criteria, namely CMIN / DF, RMSEA, show good models. According to Gozali (2014), the best criteria used as an indication of the goodness of fit of the model was the value of Chi Square / DF to be less than 2, and RMSEA to be below 0.08. In this study, the value of the CMIN / DF and RMSEA have met the cut-off value. Therefore, the SEM model in this study is suitable and feasible to use which also result in further interpretation for further discussion. If two or more of the entire GOF used have shown a good fit, the model is considered good.

4.4 Analysis of The Influence of Entrepreneurship towards Social Entrepreneurship

The structural model presents the relationship between the research variables. The structural model coefficient shows the relationship between variables. There is a significant influence if the P-value is < 0.05. In the SEM, there are two influences which are direct and indirect influences. The following figure 2 depicts the results of the analysis of direct and indirect influence.

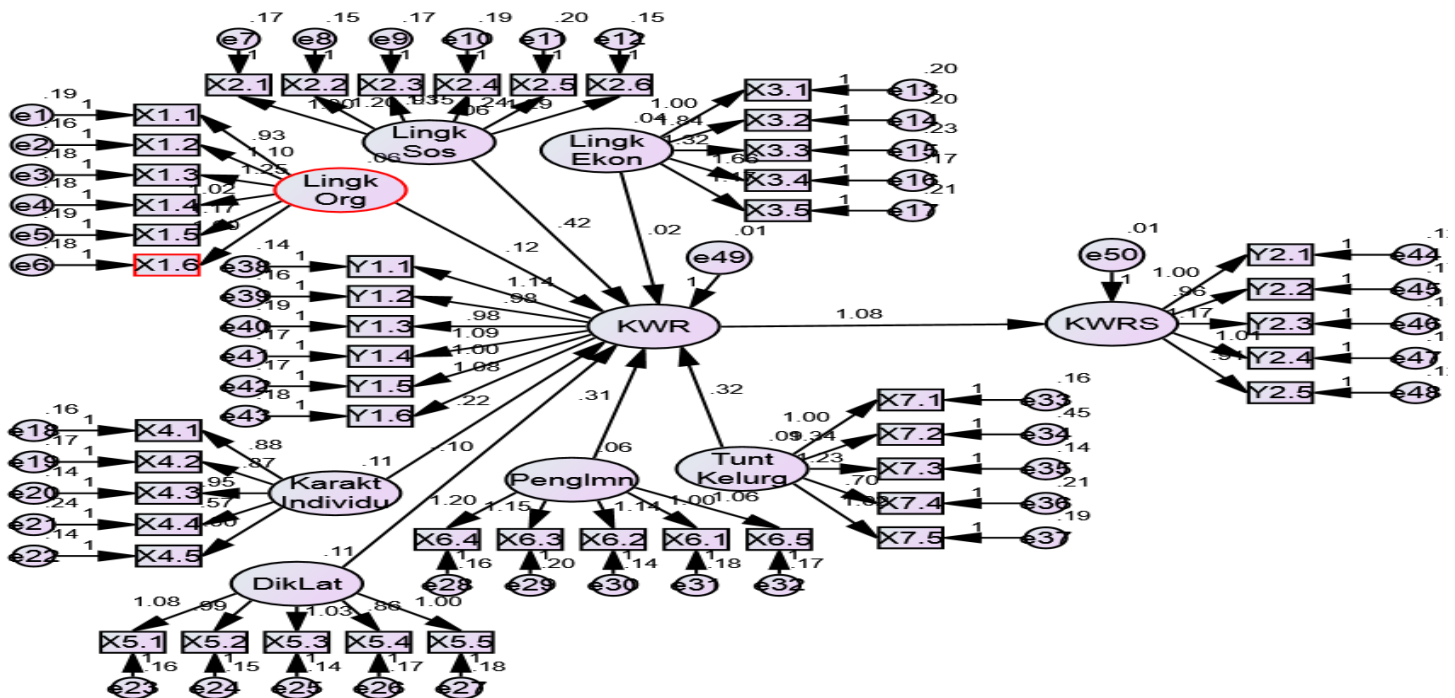

Figure 2. The Full structural equation model*Source: the authors*

Notes:

KWR	: Entrepreneurship (E)
KWRS	: Social Entrepreneurship (SE)
Lingk Org	: Organizational Environment (OE)
Lingk Sos	: Social Environment (SocE)
Lingk Ekon	: Economic Environment (EcoE)
Karakt Individu	: Individual Characteristic (IC)
DikLat	: Education and Training (ET)
Penglmn	: Experience (Ex)
Tunt Kelurg	: Family Demands (FD)

Based on the results of the indirect influence of social entrepreneurship, it shows that it is not significant. It indicated that the entrepreneurship variable was not the intervening variable. The previous researches looked at entrepreneurship as a separate part of social entrepreneurship (McMullen, 2011; Kimmit & Muñoz, 2018; Daud et al., 2018). In accordance with the description, this research was done as an attempt to conduct an in-depth study of how to build a social entrepreneurship model (Sannikova & Brante, 2018). The results of the research conducted had answered the research problem significantly. Based on the analysis, the second and third model could be proposed where the second model would examine the influence of the external environment on social entrepreneurship, and the third model would examine the influence of the external environment on social entrepreneurship by mediating the entrepreneurship variables as the intervening variables. The second model results are the direct influence of external and internal variables, which include organizational environment variables, social environment, economic environment, individual characteristic, education and training, experience, and family demands influencing the social entrepreneurship, except the organizational environment. Then, the third step was to examine the influence of the organizational environment, social environment, economic environment, individual characteristic, education and training, experience, and family demands toward the social entrepreneurship with the entrepreneurship variables as intervening variables. The direct influence of entrepreneurship on social entrepreneurship, which shows that the influence of entrepreneurial relations on social entrepreneurship is significant and positive. The results of this study are supported by the results of the study by Estrin et al. (2013) and Myres et al. (2018) which showed that the high number of commercial entrepreneurs in one country will determine the number of social entrepreneurs. Therefore, it could be concluded that there was a link between entrepreneurship and social entrepreneurship (Abdulmelike, 2017; Myres et al., 2018; Buchko, 2018; Kimmit & Muñoz, 2018; Sannikova & Brante, 2018; Prodanov, 2018; Shin, 2018; Daud et al., 2018; European Commission, 2018; Gandhi & Raina, 2018). Furthermore, based on the results of the analysis of the indirect influences of organizational environment variable, social environment, economic environment, individual characteristic, education and training, experience, and family demands on social entrepreneurship with entrepreneurship variables as the intervening variables, it shows that it has a significant influence, except economic environment variables. Based on the analysis of direct and indirect influences, the empirical model as the third model shows that the entrepreneurship variable was able to function as an intervening variable that mediates the relationship of independent variables with the social entrepreneurship. Likewise, based on the SEM analysis, the independent variable had an influence on social entrepreneurship, with the entrepreneurship variable as the intervening variable. However, there was one economic environment variable, that did not have a significant influence on the variables of social entrepreneurship. Further, the third model shows that the influence of entrepreneurship variable on the social entrepreneurship is significant. This result filled in the research gap of this research. It claims that there are inconsistencies between the research results by McMullen (2011) and Estrin et al. (2013). This was also in line with the opinion of Peredo and McLean (2006) explaining that social entrepreneurship is formed when individuals or groups of people: (1) aim to create social value, either exclusively or at least in some acceptable ways; (2) demonstrate the capacity to recognize and take advantage of opportunities to create values; (3) create innovation, starting from direct discovery or by adapting ways to create and or

distribute social values; (4) willing to accept the level of risk above the average in creating and spreading social values.

Conclusions

First, based on the results of the social entrepreneurship model analysis, it was found that the direct influence of the organizational environment, social environment, individual characteristic, experience, and family demands was significant and positive towards entrepreneurship, while the economic environment and training education had no significant influence on entrepreneurship. The results of the analysis also showed that all variables had a direct influence on social entrepreneurship, except for the organizational environment variables. Second, based on the results of the analysis, all variables did not have an indirect influence on social entrepreneurship. Third, based on the second model of social entrepreneurship, the analysis revealed that organizational environment variables, social environment, economic environment, individual characteristic, education and training, experience, and family demands indirectly influenced the social entrepreneurship with entrepreneurship as the intervening variable, except the economic environment variable.

Future researches can be developed by adding models of industrial factors other than agricultural and educational factors. The role of government in this study has also not been analyzed in the model, although theoretically it is alluded to. The government plays a role in correcting through various policies and institutions. Future researches can also develop models, which add governmental factors. It can be done by comparing government policies in the agricultural, industrial, and education sectors or by using secondary data in a longer period.

References

- Abdulmelike, A. 2017. Social Entrepreneurship: Literature Review and Current Practice in Ethiopia. *European Journal of Business and Management*, 9(31), 86-93. Retrieved from <https://www.iiste.org/Journals/index.php/EJBM/article/view/39601/40719>
- Alvord, S. H.; Brown, D. L.; & Letts, C. W. 2004. Social Entrepreneurship and Societal Transformation: An Exploratory Study. *Journal of Applied Behavioural Science*, 40(3), 260-282. Retrieved from <http://citeseerx.ist.psu.edu/viewdoc/download?doi=10.1.1.321.8660&rep=rep1&type=pdf>
- Bornstein, D. 2004. *How to Change the world: Social Entrepreneurship and the power of new ideas*. New York: Oxford University Press.
- Buchko, T. 2018. Social Entrepreneurship and Its Implications for Hungary. *Periodica Polytechnica Social and Management Sciences*, 26(1), 36-48. Retrieved from <https://doi.org/10.3846/bme.2018.2198>
- Dahama, O. P.; & Bhatnagar, O. P. 1980. *Training principles and practices: Education and Communication for Development*. New Delhi: Oxford and IBH Publishing Company Pvt Ltd.
- Daud, N. S.; Ishak, S. I. D.; Abdullah, S.; Azmi, A. A.; Ishak, A. S.; & Ahmad, A. 2018. The Discussion of Social Entrepreneurship: Review of the Literature. *MATEC Web of Conferences*, 150, 1-8. Retrieved from https://www.mateconferences.org/articles/mateconf/pdf/2018/09/mateconf_mucet2018_05095.pdf
- Drucker, P. F. 1996. *Inovasi dan Kewiraswastaan: Praktek dan dasar-dasar*. Jakarta: Erlangga.
- European Commission. 2018. *Peer Review on Social Entrepreneurship to tackle unmet social challenges*. Oslo: Directorate-General for Employment, Social Affairs and Inclusion. Retrieved from <https://ec.europa.eu/social/BlobServlet?docId=19230&langId=en>
- Epstein, M. J.; & Crane, C. A. 2007. *Alleviating global poverty through microfinance: Factors and measures of financial, economic, and social performance*. San Francisco: Jossey-Bass.
- Estrin, S.; Mickiewicz, T.; & Stephan, U. 2013. Entrepreneurship, Social Capital, and Institutions: Social and Commercial Entrepreneurship across Nations. *Journal of Entrepreneurship Theory and Practice*, 37(3), 479-503. Retrieved from <https://scihub.tw/https://onlinelibrary.wiley.com/doi/abs/10.1111/etap.12019>

- Ghandi, T.; & Raina, R. 2018. Social entrepreneurship: the need, relevance, facets and constraints. *Journal of Global Entrepreneurship Research*, 8(9), 1-13. Retrieved from https://cpr.bu.edu/app/uploads/2018/07/Social_entrepreneurship_the_n.pdf
- Ghozali, I. 2014. *Structural Equation Modeling: Metode Alternatif dengan Partial Least Square (PLS)*. Semarang: Badan Penerbit Universitas Diponegoro.
- Greenhaus, J.; & Singh, R. 2003. *Work-Family Linkages, A Sloan Work and Family Encyclopedia Entry*. Chestnut Hill: Boston College.
- Harrington, D. 2009. *Confirmatory Factor Analysis*. New York: Oxford University Press, Inc.
- Hibbert, S. A.; Hogg, G.; & Quinn, T. 2002. Consumer response to social entrepreneurship: the case of the Big Issue in Scotland. *International Journal of Nonprofit & Voluntary Sector Marketing*, 7(3), 288-301. Retrieved from <https://scihub.tw/https://onlinelibrary.wiley.com/doi/abs/10.1002/nvsm.186>
- Hisrich, R. D.; & Peters, M. P. 1992. *Entrepreneurship, Starting, Developing, and Managing a New Enterprise* (2nd ed.). New York: Irwin Publishing Ltd.
- Kadarsih, R.; Susilaningih; & Sumaryati, S. 2013. Faktor – faktor yang mempengaruhi minat berwirausaha pada Mahasiswa Program Studi Pendidikan Ekonomi FKIP UNS. *Jurnal Pendidikan UNS*, 2(1), 95-106. Retrieved from <http://jurnal.fkip.uns.ac.id/index.php/ekonomi/article/view/2708>
- Kimmit, J.; & Muñoz, J. 2018. Sensemaking the ‘social’ in social entrepreneurship. *International Small Business Journal: Researching Entrepreneurship*, 36(8), 859-886. Retrieved from <https://doi.org/10.1177/0266242618789230>
- Kirzner, I. M. 1973. *Competition and Entrepreneurship*. Chicago: University of Chicago Press.
- Mair, J.; & Noboa, E. 2003. The Emergence of Social Enterprises and Their Place in the New Organizational Landscape. *IESE Working Paper 253 Barcelona*. Retrieved from <https://core.ac.uk/download/pdf/6536275.pdf>
- Mazzarol, T.; Volery, T.; Doss, N.; & Thein, V. 1999. Factors Influencing Small Business Start-Ups: A comparison with previous research. *International Journal of Entrepreneurial Behaviour & Research*, 5(2), 48-63. Retrieved from <https://pdfs.semanticscholar.org/6699/5f7cc5df18730f9cd6e55973201154599a65.pdf>
- McMullen, J. S. 2011. Delineating the domain of development entrepreneurship: A market based approach to facilitating inclusive economic growth. *Entrepreneurship Theory and Practice*, 35(1), 185–193. Retrieved from https://www.effectuation.org/wp-content/uploads/2017/06/McMullen-2011-Entrepreneurship_Theory_and_Practice.pdf
- Meredith, G. G.; Nelson, R. E.; & Neck, P. A. 1996. *Kewirausahaan, Teori dan Praktek*. Jakarta: PT Pustaka Binaman Pressindo.
- Myres, K.; Mamabolo, A.; Mugudza, N.; & Jankelowitz, L. 2018. *Social Enterprises in South Africa: Discovering a vibrant sector*. Pretoria: Gordon Institute of Business Sciences. Retrieved from https://www.gibs.co.za/programmes/the-centre-for-leadership-anddialogue/Documents/18103%20Stakeholder%20Report_FINAL.pdf
- Mohapatra, S.; Khadanga, G. S.; & Majhi, S. 2018. Social entrepreneurship for agricultural development in India. *The Pharma Innovation Journal*, 7(4), 204-205. Retrieved from <http://www.thepharmajournal.com/archives/2018/vol7issue4/PartD/7-3-73-624.pdf>
- Mort, G. S.; Weerawardena, J.; & Carniege, K. 2003. Social entrepreneurship: Towards conceptualisation. *International Journal of Nonprofit and Voluntary Sector Marketing*, 8(1), 76-88. Retrieved from <https://scihub.tw/https://onlinelibrary.wiley.com/doi/abs/10.1002/nvsm.202>
- Mustofa, Y. 1996. *Teknik Wiraswasta Dalam Keluarga*. Jakarta: Rineka Cipta.
- Nicholls, A. 2006. *Social Entrepreneurship: New Models of Sustainable Social Change*. USA: Oxford University Press.
- Prabhu, G. N. 1999. Social Entrepreneurial Leadership. *Career Development International*, 4(3), 140-145. Retrieved from <http://dx.doi.org/10.1108/13620439910262796>
- Peredo, A. M.; & McLean, M. 2006. Social entrepreneurship: a critical review of the concept. *Journal of World Business*, 41(1), 56–65. Retrieved from <http://www.sciencedirect.com/science/article/pii/S1090951605000751>

- Priyanto, S. H. 2004. Pengaruh Lingkungan eksternal, kewirausahaan dan kapasitas manajemen terhadap kinerja usaha tani: Studi empiris pada petani tembakau di Jawa Tengah. *Dissertation*. Program Studi Ilmu Ekonomi Pasca Sarjana Universitas Brawijaya.
- Prodanov, H. 2018. Social Entrepreneurship and Digital Technologies. *Economic Alternatives*, 1, 123-138. Retrieved from https://www.unwe.bg/uploads/Alternatives/9_Prodanov_EAlternativi_en_1_2018.pdf
- Riyanti, B. P. D. 2003. *Kewirausahaan dari sudut pandang psikologi kepribadian*. Jakarta: Grasindo.
- Repetti, R. L.; Taylor, S. E.; & Seeman, T. E. 2002. Risky families: Family social environments and the mental and physical health of offspring. *Psychological Bulletin*, 128(2), 330-366. Retrieved from <http://dx.doi.org/10.1037/0033-2909.128.2.330>
- Sadoulet, E.; & de Janvry, A. 1995. *Quantitative Development Policy Analysis*. Baltimore: The Johns Hopkins University Press.
- Sannikova, A.; & Brante, I. 2018. Development of Social Entrepreneurship in Latvia. *Business, Management and Education*, 16(1), 147-159. Retrieved from <https://doi.org/10.3846/bme.2018.2198>
- Santoso, S. 2012. *Analisis SEM Menggunakan AMOS*. Jakarta: Elex Media Komputindo.
- Siagian, S.; & Asfahani. 1995. *Kewirausahaan Indonesia dengan Semangat*. Jakarta: Kloang Klede Jaya Putra Timur.
- Sharir, M; Lerner, M. (2006). Gauging the success of social ventures initiated by individual social entrepreneurs. *Journal of World Business*, 41(1), 6-20. Retrieved from <http://www.sciencedirect.com/science/article/pii/S1090951605000568>
- Shin, C. 2018. How Social Entrepreneurs Affect Performance of Social Enterprises in Korea: The Mediating Effect of Innovativeness. *Sustainability*, 10(8), 1-14. Retrieved from <https://www.mdpi.com/2071-1050/10/8/2643>
- Thompson, J.; Alvy, G.; & Lees, A. 2000. Social Entrepreneurship - A New Look At the People and the Potential. *Management Decision*, 38(5), 328-338. Retrieved from <http://dx.doi.org/10.1108/00251740010340517>
- Umar, T. R.; Mat, N. K. N.; Tahir, F. A.; & Alekam, J. M. 2012. The Practicality and Application of Aaker's Customer Based Brand Equity Model in the Nigerian Banking Sector. *American Journal of Economics, Special Issue*(June), 149-152. Retrieved from <http://article.sapub.org/pdf/10.5923/j.economics.20120001.33.pdf>
- Soemanto, W. 2002. *Pendidikan Wiraswasta*. Jakarta: Bumi Aksara.
- Wijayanto, S. 2008. *Structural Equation Modelling dengan LISREL 8.8: Konsep dan Tutorial*. Yogyakarta: Graha Ilmu.
- Wijono, S. 2005. Pengaruh Kepribadian Tipe A, Locus of Control External, Peran dan Iklim Organisasi Terhadap Stress dan Prestasi Kerja dengan Prestasi Kerja. *Dissertation*. Universitas Indonesia.

Hardi UTOMO MM. is a Doctoral student in Department of Doctor Management Science at the Faculty of Economics and Business of Satya Wacana Christian University, Indonesia.

ORCID ID: <https://orcid.org/0000-0003-2281-6804>

Prof. Sony Heru PRIYANTO is a lecturer in Department of Doctor Management Science at the Faculty of Economics and Business of Satya Wacana Christian University, Indonesia.

ORCID ID: <https://orcid.org/0000-0002-5016-1748>

Lieli SUHARTI PhD is a lecturer in Department of Doctor Management Science at the Faculty of Economics and Business of Satya Wacana Christian University, Indonesia.

ORCID ID: <https://orcid.org/0000-0003-4538-9569>

Dr. Gatot SASONGKO is a lecturer in Department of Doctor Management Science at the Faculty of Economics and Business of Satya Wacana Christian University, Indonesia.

ORCID ID: <https://orcid.org/0000-0003-0381-9348>

Copyright © 2019 by author(s) and VSI Entrepreneurship and Sustainability Center

This work is licensed under the Creative Commons Attribution International License (CC BY).

<http://creativecommons.org/licenses/by/4.0/>

